

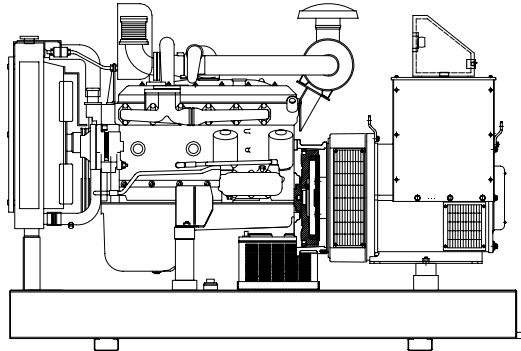

MAQUINARIA IGSA POWER GENERATION SYSTEMS



MODEL: GSIV00100S
DIESEL ENGINE: IVECO
MODEL: 806ISi07
CAPACITY: 100 KW 60 HZ

RATINGS RANGE	
PRIME HP(KW)	STANDBYHP(KW)
142 (106)	146 (119)

Ratings in accordance with ISO 8528-standard reference conditions:

Air inlet temperature	25°C (77°F)
Pressure	1000 mbar (14.5psi)
Relative humidity	30%
Power factor	0.8

STANDARD FEATURES

Complete system designed and built at ISO9001 certified facility

- Factory tested to design specifications at full load conditions.
- Fully engineered with a range of options and accessories.

1 IGSA Genset's are composed of 6 cylinders in line and four strokes diesel engine for industrial stationary applications. Those equipments are fully factory tested using a resistive load. (1) Hour ramp 100% load test.

2 The controls and accessories are selected to work together to achieve the maximum operational performance and security.

3 Exhaust gases silencer, and a section of flexible tube for connection purposes.

4 Engine IVECO, **806ISi07**

5 Marathon or Stamford Alternator.

6 Control 310 (panel USC300)

7 Radiator

8 Base of structural steel.

General Features

- IGSA GENSET of, **100 kW to 480V, 440V, 380V, 220V, 208V, 190VAC, 60Hz**, is composed by an internal engine four strokes coupling with the alternator, controls and accessories totally assembled and tested in factory.
- The controls and accessories of the Genset are selected to provide the maximum in efficiency and Security
- The generator set its components are tested factory-built, and production-tested.
- Speed governor electronic (G3 class)

ENGINE SPECIFICATION DATA MODEL 806ISi07

Weight 580 Kg (1279 Lb)

General Data	
Model	806ISi07
Diesel 4 Stroke-Injection type	direct
Number of Cylinders	6 in line
Total Displacement-- gl (L)	1.6 (5.9)
Bore x Stroke--in.(mm)	41 x 45.3 / 104 x 115
Compression Ratio	18:01
Aspiration	turbocharged
Cooling system	liquid (water + 50% Parafllu I I)
Lube oil specifications	ACEA E3-API CF4/MILL2104E/F
Lube oil consumption	< 0.3% of fuel consumption
Fuel specification	EN 590
Speed governor	electronic (G3 class)
Engine rotating mass	
moment of inertia-- kg.m ² / lb/ft ²	1.173 / 27.8
Flywheel housing / Flywheel	SAE/11" ½
Physical Data	
Length--in.(mm)	56.9 (1446)
Width--in.(mm)	26.8 (680)
Height--in.(mm)	43.9 (1115)
Weight, dry--lb (kg)	1279 (580)
Fuel Consumption at 1800 RPM -- gl/hr (l/hr)	
BMEP	1196
100 % Power	7.2 (27.1)
75 % Power	5.5 (20.7)
50 % Power	3.7 (14.1)
Air Induction System	
Intake air Flow m ³ /h / ft ³ /h	490/ 17304.19
Maximum suggested intake restrictions:	
with clean air filter kPa psi	2.45 / 0.355
with dirty air filter kPa psi	4.9 / 0.711
Injection	
Injection System	mechanical
Max speed drop steady conditions.	isochronous
Max fuel feed pump suction head in/m	31.5 / 0.8

Exhaust System	
Exhaust gas flow-- kg/h / lb/h	590 / 1300.7
Max exhaust temperature at full load (at 25°C/ 77°F - after turbine)-- °C/°F	440 / 824
Max allowable exhaust backpressure-- kPa	4.9 / 0.711
Cooling System	
Cooling System:	
engine only-- gl (L)	3.0 (11.5)
engine + Radiator-- gl (L)	5.7 (21.5)
Cooling water flow rate-- l/min / j/min	105 / 27.4
Max allowable pressure drop on external water circuit.—kPa / psi	9.8 / 1.421
Max head of cooling radiator—m/ft	3 / 9.8
Pusher fan air flow-- m ³ /s / m/ft ²	2 / 70.63
Pusher fan head (static)—kPa / psi	392 / 56.84
Pusher fan absorbed power—kW / hp	1.6 / 2.146
Max engine outlet water temp. (Alarm)-- °C / °F	100 / 212
ATB (without canopy)- nominal rating-- °C / °F	50 / 122
Lubrication System	
Lube oil total system incl. Sump, filters etc.-- kg(lb)	13 (14.3)
Oil capacity of standard sump:	
at min. Level-- kg(lb)	9 (10)
at max. -- kg(lb)	11 (12)
Maximum oil temperature-- °C / °F	120 / 248
Oil pressure (min/max)-- kPa	196 / 28.42
Heat Rejection (at full load conditions)	
Engine to coolant (Water + oil)-- kcal/kWh	550
Engine to exhaust-- kcal/kWh	615
Radiated to ambient-- kcal/kWh	130
Electrical Starting System	
Cranking motor rating—kW / hp	3 / 4.02
Auxiliary voltage-- Vcc	12
Battery-charge alternator-- A	45
Starting batteries:	
Recommended capacity-- Ah	100
Discharge current-- A	650



WE ARE THE BEST IN MANUFACTURING THE POWER GENERATION SYSTEMS AND ADDITION CONSTANTLY INNOVATION.

www.icsa.com.mx
All rights reserved.
Printed in MEXICO

MARATHON ELECTRIC ALTERNATOR MODEL 362PSL1606
Weight 361 kg (796Lb)

Voltage	1800 RPM			60 Hertz			12 Leads standard 3 phase		
	3 Phase			0.8 Power Factor			Dripproof or Open Enclosure		
	Class B			Class F			Class H		
	80°C/176°F (1)	90°C/194°F(1)	95°C/203°F(1)	105° C / 221°F†	105°C / 221°F	130°C/266°F(1)	125° C / 257 °F †	125°C / 257°F	150°C/302°F(1)
	Continuous	Lloyds	ABS	British Standard	Continuous	Standby	British Standard	Continuous	Standby
480/240	80 (100)	83 (104)	83 (104)	96(120)	96(120)	105 (131)	105 (131)	105 (131)	113 (141)
460/230	80 (100)	83 (104)	83 (104)	96 (120)	96 (120)	105 (131)	105 (131)	105 (131)	113 (141)
440/220	82 (103)	84 (105)	84 (105)	92 (115)	92 (115)	102 (128)	102 (128)	102 (128)	107 (134)
416/208	80 (100)	82 (103)	82 (103)	90 (113)	90 (113)	100 (125)	100 (125)	100 (125)	105 (131)
380/190	72 (90)	75 (93.8)	75 (93.8)	81 (101)	81 (101)	90 (113)	90 (113)	90 (113)	95 (119)

(1) Rise by resistance method, Mil-Std-705, Method 680.1b.

† Rating per BS 5000.

Submittal Data: 480 Volts, 100 kw, 125 kVA, 0.8 P.F., 1800 RPM, 60 Hz, 3 Phase					
Mil-Std-705C			Mil-Std-705C		
Method	Description	Value	Method	Description	Value
301.1b	Insulation Resistance	> 1.5 Meg	505.3b	Overspeed	2250 RPM
302.1a	High Potential Test		507.1c	Phase Sequence CCW-ODE	ABC
	Main Stator	2000 Volts	508.1c	Voltage Balance L-L OR L-N	0.20%
	Main Rotor	1500 Volts	601.4a	L-L Harmonic Maximum - Total	3.5%
	Exciter Stator	1500 Volts		(Distortion Factor)	
	Exciter Rotor	1500 Volts	601.4a	L-L Harmonic Maximum - Single	2.5%
401.1a	Stator Resistance, Line to Line		601.1c	Deviation Factor	7.0%
	High Wye Connection	0.098 Ohms	--	TIF (1960 Weightings)	<50
	Rotor Resistance	1.2 Ohms	--	THF (IEC, BS & NEMA Weightings)	<2%
	Exciter Stator	23.5 Ohms	652.1a	Shaft Current	<0.1 ma
	Exciter Rotor	0.12 Ohms	--	Main Stator Capacitance to ground	@NA mdf
410.1a	No Load Exciter Field Amps			Additional Prototype Mil-Std Methods	
	at 240/480 Volts Line to Line	0.46 A DC		are Available on Request.	
420.1a	Short Circuit Ratio	0.536	--	Generator Frame	362
421.1a	Xd Synchronous Reactance	2.1 pu	--	Type	Magnaplus
422.1a	X2 Negative Sequence	0.109 pu	--	Insulation	Class H
423.1a	X0 Zero Sequence Reactance	0.035 pu	--	Coupling - Single Bearing	Flexible
425.1a	X'd Transient Reactance	0.138 pu	--	Amortisseur Windings	Full
426.1a	X''d Subtransient Reactance	0.97 pu	--	Excitation Ext. Voltage Regulated, Brushless	
427.1a	T'd Transient Short Circuit		--	Voltage Regulator	SE350
	Time Constant	0.053 sec.	--	Voltage Regulation	1%
428.1a	T''d Subtransient Short Circuit		--	Cooling Air Volume	700 CFM
	Time Constant	0.006 sec.	--	Heat rejection rate	573 Btu s/min
430.1a	T'do Transient Open Circuit		--	Full load current	150 amps
	Time Constant	0.63 sec.	--	Minimum Input hp required	147.6
432.1a	Ta Short Circuit Time		--	Efficiency at rated load:	90.8 %
	Constant of Armature Winding	0.015 sec.	--	Full load torque	431 Lb-ft

* (3) Excitation support system or PMG required to sustain short circuit currents.
 * Voltage refers to wye (star) connection, unless otherwise specified.
 ** Not supplied as standard equipment.



www.igsa.com.mx
 All rights reserved.
 Printed in MEXICO

STAMFORD ELECTRIC ALTERNATOR MODEL UC1274C

weight 392.6 kg (866Lb)

CONTROL SYSTEM	SEPARATELY EXCITED BY P.M.G.		
A.V.R.	MX321	MX341	
VOLTAGE REGULATION	(+/- 0.5%)	(+/- 1.0%)	WITH 4 ENINE GOVERNING
SUSTAINED SHORT CIRCUIT	REFERENT TO SHOT CIRCUIT DECREMENT CURRENT		

INSULATION SYSTEM	CLASS H							
PROTECTION	IP23							
RATED POWER FACTOR	0.8							
STATOR WINDING	DOUBLE LAYER CONCENTRIC							
WINDING PITCH	TWO THIRDS							
WINDING LEADS	12							
STATOR WDG. RESISTANCE	0.059 Ohms PER PHASE AT 22°C SERIES STAR CONNECTED							
ROTOR WDG. RESISTANCE	0.12 Ohms at 22°C							
R.F.I. SUPPRESSION	BS EN 61000-6-2 & BS EN 61000-6-4, VDE 0875G, VDE 0875N. refer to factory for others							
WAVEFORM DISTORTION	NO LOAD < 1.5% NON-DISTORTING BALANCED LINEAR LOAD < 5.0%							
MAXIMUM OVERSPEED	2250 Rev/Min							
BEARING DRIVE END	BALL. 6315 - 2RS. (ISO)							
BEARING NON-DRIVE END	BALL. 6310 - 2RS. (ISO)							
WEIGHT COMP. GENERATOR	1 BEARING				2 BEARING			
	406 kg / 896 lb				420 kg / 926 lb			
WEIGHT WOUND STATOR	131 kg / 289 lb				131 kg / 289 lb			
WEIGHT WOUND ROTOR	13.78 Kg / 30.4				122.82 kg			
WR² INERTIA	1.0288 kg/m ² / 24.4 lb/ft ²				0.9781 kg/m ² / 23.2 lb/ft ²			
SHIPPING WEIGHTS in a crate	439 kg / 967.8 lb				452 kg / 996.5 lb			
PACKING CRATE SIZE	105 x 67 x 103 (cm) 3.45x2.2x3.38 (in)				105 x 67 x 103 (cm) 3.45x2.2x3.38 (in)			
TELEPHONE INTERFERENCE	50 Hz				60 Hz			
COOLING AIR	THF<2%				TIF<50			
	0.514 m ³ /sec 1090 cfm				0.617 m ³ /sec 1306 cfm			
VOLTAGE SERIES STAR	380/220	400/231	415/240	440/254	416/240	440/254	460/266	480/277
VOLTAGE PARALLEL STAR	190/110	200/115	208/120	220/127	208/120	220/127	230/133	240/138
VOLTAGE SERIES DELTA	220/110	230/115	240/120	254/127	240/120	254/127	266/133	277/138
KVA BASE RATING FOR	100	100	100	N/A	112.5	117.5	117.5	125
RECTANCE VALUES								
X_d DIR. AXIS SYNCHRONOUS	2.45	2.21	2.05	N/A	2.76	2.58	2.36	2.30
X'_d DIR. AXIS TRANSIENT	0.20	0.18	0.17	-	0.24	0.22	0.21	0.20
X''_d DIR. AXIS SUBTRANSIENT	0.14	0.13	0.12	-	0.16	0.15	0.14	0.13
X_q QUAD. AXIS REACTANCE	1.59	1.43	1.33	-	1.58	1.48	1.35	1.32
X''_q QUAD. AXIS SUBTRANSIENT	0.18	0.16	0.15	-	0.23	0.21	0.20	0.19
XL LEAKAGE REACTANCE	0.07	0.06	0.06	-	0.08	0.07	0.07	0.07
X₂ NEGATIVE SEQUENCE	0.16	0.14	0.13	-	0.19	0.18	0.16	0.16
X₀ ZERO SEQUENCE	0.10	0.09	0.08	-	0.12	0.11	0.10	0.10
REACTANCES ARE SATURATED				VALUES ARE PER UNIT AT RATING AND VOLTAGE INDICATED				
T'_d TRANSIENT TIME CONST.	0.28 s							
T''_d SUB-TRANSTIME CONST.	0.001 s							
T'_{do} O.C. FIELD TIME CONST.	0.8 s							
T_a ARMATURE TIME CONST.	0.07 s							
SHORT CIRCUIT RATIO	1/X _d							

• Voltage refers to wye (star) connection, unless otherwise specified

RATINGS: All three-phase units are rated at 0.8 power factor. All single-phase units are rated at 1.0 power factor. Standby Ratings: Standby ratings apply to installations served by a reliable utility source. The standby rating is applicable to varying loads for the duration of a power outage. There is no overload capability for this rating. Ratings are in accordance with ISO-3046/1, BS5514, AS2789, and DIN 6271. Prime Power Ratings: Prime power ratings apply to installations where utility power is unavailable or unreliable. At varying load, the number of generator set operating hours is unlimited. A 10% overload capacity is available for a 12 hours period. Ratings are in accordance with ISO-8528/1, overload power in accordance with ISO-3046/1, BS 5514, AS 2789, and DIN 6271. For limited running time and base load ratings, consult the factory. The generator set manufacturer reserves the right to change the design or specifications without notice and without any obligation or liability whatsoever. **GENERAL GUIDELINES FOR DERATION:** Altitude: Derate 0.5% per 100 m (328 ft.) elevation above 2000 m (6560 ft.). Temperature: Derate 1.0% per 10°C (18°F) temperature above 40°C (104°F).



WE ARE THE BEST IN MANUFACTURING THE POWER GENERATION SYSTEMS AND ADDITION CONSTANTLY INNOVATION.

www.igs.com.mx
All rights reserved.
Printed in MEXICO

CONTROLLER FOR GENSET: MEC310

The Generator Controller MEC 310 is a microprocessor-based control unit containing all necessary functions for protection and control of a power generator. Besides the control and protection of the diesel engine it contains a full 3-phase AC voltage and current measuring circuit. The unit is equipped with an LCD display presenting all values and alarms.



- USC 300C Unit Mount Control Panel, Black Nema 1 enclosure c/w rubber mounts
 - MEC 310 Microprocessor Based Engine Generator Controller
 - Graphic Display 128 X 64 pixels (STN) Super Twisted Nematic
 - Digital AC Metering:
 - 3-Phase Volts (Phase to Phase and Phase to Neutral),
 - 3-Phase Amps
 - Frequency
 - kW, kVAR, KVA, pF, kWhr
- AC Protective Relaying:
 - 27/59 Under/Over Voltage
 - 32 Reverse Power
 - 51 Time Overcurrent
 - 81 O/U Under/Over Frequency
 - Digital gauge display:
 - Oil Pressure (sender required by others)
 - Coolant Temperature (sender required by others)
 - Fuel Level (sender required by others)
 - Hourmeter
 - Tachometer
- 5 digital inputs for alarms / shutdowns
 - Dedicated Output Contacts - Engine Crank; Run (30 VDC / 6 Amps)
 - Three Programmable Output Contacts (30 VDC / 1 Amps)
 - Event Logging (30 events)
 - Pushbuttons:
 - Emergency Stop
 - Manual Start and Stop
 - Manual/Auto/Test
 - Lamp Test
 - Horn Silence
 - Indicating Lights:
 - Common Alarm
 - Generator Ready (Voltage and Frequency Normal)

FEATURES

- Electrical Rating:**
- Single or three phase, 600VAC maximum, 50/60HZ, 4 wire
 - 12 or 24Vdc (nominal) supply, negative ground.
 - Dedicated Output Contacts - Engine Crank; Run (30 VDC / 6 Amps)
 - Three Programmable Output Contacts (30 VDC / 1 Amps)
- Enclosure:**
- Black Nema 1 enclosure c/w rubber mounts
- Engine Senders:**
- Oil pressure (1/8" NPT), Temperature (1/4"NPT) (Supplied loose for engine mounting).
- Requirements:**
- Exceeds requirements of CSA 282 and NFPA 110 Level

OPTIONAL SILENCER ACCORDING TO THE APPLICATION

Silencer with different levels from attenuation

- Critical Grade
- Super Critical Grade
- Hospital Grade

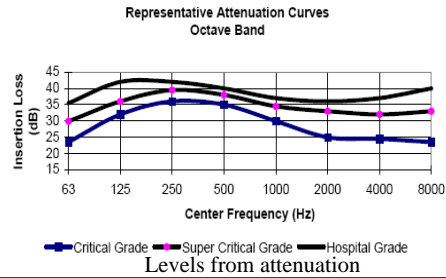

DOCUMENTATION AND OTHERS

- Manual of operation and maintenance
- Spare parts
- Maintenance
- Consulting

MISCELLANEOUS EQUIPMENT

- Batteries of 12 VDC with cables for battery connection with the Engine.

GENSET OPTIONS

Control Panel

USC 300C Control Panel is standard on all units see page 4 of spec sheet for standard features.

Another Type _____

Fuel system

- Fuel Water Separator
- Day tank
- Auxiliary fuel pump
- Sub Base mounted Fuel Tank
 - Single Wall
 - Double Wall
 - UL listed
 - 150 L (39.6 gal)
 - 250 L (66 gal)

Diesel Fuel Tank

- 500 L (132 gal)
- 1000 L (264.1 gal)
- 5000 L (1320.8 gal)

Exhaust System

- Critical Grade
- Super Critical Grade
- Hospital Grade

Engine Electrical system

- Battery
 - Lead-Acid
 - NiCad
- Battery Rack
- Battery Charger Automatic

Generator

- Breaker in the alternator

OPTIONAL ACCESSORIES AVAILABLE FOR THE EQUIPMENT

Vibration isolation

- Rigid Spring Mounting
- Resilient Mounting

Filters

- Air Filter for Medium Dust Environments
- Air Filter of Heavy Dust Environments

Drain

- Oil drain Extension

Enclosures

- Sound Attenuated
- Weather Proof
- Stainless steel cover
- Trailer Mounting
- Interior lights Ac or DC

Heaters

- Jacket Water Heater
- Crankcase Oil Heater

Insulation Blankets

- Features:
(Temperature to 1260°C (2300°F), Non-Combustible, Highly Resistant to Vibration, Oil, Fuel, Grease, and Moisture Resistant Exterior, Personal Protection

Notes



WE ARE THE BEST IN MANUFACTURING THE POWER GENERATION SYSTEMS AND ADDITION CONSTANTLY INNOVATION.

www.iqsa.com.mx
All rights reserved.
Printed in MEXICO

DIMENSIONS

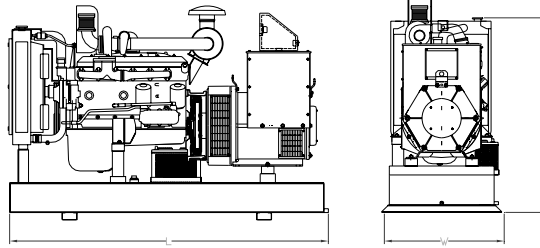

LENGTH	WIDTH	HEIGHT
MM(IN)	MM(IN)	MM(IN)
2260 (89)	800 (31)	1530 (60)

NOTE: General configuration not to be used for installation. See general dimension drawing for detail.

SERVICES

- Development of the project.
- Development of engineering.
- Equipment's Installation
- Engineering for special applications.
- Synchronies with utility network or more Gensets.
- Attention and technical support

INSTALLATION OPTIONS OF THE GENSET

- On-Site
- Acoustic Enclosure
- ISO Container
- Trailer



FECHA	No. de REV.	ELABORO	REVISO	APROBO
30 julio 2007	01	<p>_____ Ing. Hugo Reyes E. Ing. de Aplicación.</p>	<p>_____ Ing. Hugo Orozco. Gerente Ing.</p>	<p>_____ Ing. Cesar Romero R. Dir. Proyectos Esp.</p>



WE ARE THE BEST IN MANUFACTURING THE POWER GENERATION SYSTEMS AND ADDITION CONSTANTLY INNOVATION.